

RDM-Apps

Capability Statement

Contact Information



Voltage Amplifier Modules ... Both Precision and High Speed Amplifiers

Current to Voltage Converter Modules... Pico-Amp, Nano-Amp, Milli-Amp ... 1A, 10A/V, 100A/V

Transimpedance Amplifiers... Pico-Amp, Nano-Amp, Milli-Amp ... 1A, 10A/V, 100A/V

Constant Current Source / Sink Modules... $\pm 10\text{pA}$ to 125mA, 1A, 5A & 10A full range output modules

Voltage to Constant Current Converter Modules... $\pm 10\text{pA}$ to 125mA, 1A, 5A & 10A full range output modules

Precision Isolation Amplifiers

**CONTINUE TO NEXT PAGE FOR
DOCUMENTATION**

-
-
-

RDM-Apps Setup – PCB Revs.1.xx - CSE CSE00GL-100-xx-20V-BFL Constant Current Source / Sink Module.
Voltage to Current Converter Module.

Don't waste your time designing and/or packaging a Constant Current output Op-Amp or Voltage to Current Conversion amplifier circuit for your application. Utilize one of our self contained Ready Modules for your application or simply use in conjunction with a basic Multimeter as an inexpensive alternative to an expensive Constant Current Source.

Other Related Constant Modules:

[High Current Constant Current Source / Sink Bidirectional output Modules](#)

[Voltage Amplifiers, Current to Voltage Converters ...](#)

- ◆ Adjustable Constant Current Output
- ◆ Grounded Constant Current Outputs
- ◆ Output Current Range .. better than: $\pm 100\text{mA}$
- ◆ Current Output Monitor; V_{out} proportional to current out.
- ◆ Converts from input voltage to output constant current.
- ◆ Current Output Control:
 - a.) Option#1: $\pm 10\text{V}$ input relative to applicable full range current out.
 - b.) Option#2: Manual Trim-Potentiometer adjustment .
- ◆ Offset Null Capability for calibration.
- ◆ Load Compliance Voltage better than $\pm 20\text{V}$
- ◆ Constant within a wide temperature range
- ◆ Low Power Consumption
- ◆ Contact us for multi-range or custom constant current modules.
- ◆ Contact us for single supply or lower power consumptive constant current modules.

(2 weeks Delivery, Call for order quantities greater than 5)



**RDM-Apps Setup – PCB Revs.1.xx - CSE CSE00GL-100-xx-20V-BFL Constant Current Source / Sink Module.
Voltage to Current Converter Module.**

General Specifications ...		
Desc.	Value	Unit
Operating Temperature	10 to 40	C
Required DC Supply Voltage ,, opt.1	+9V to 18Vdc	VDC
Required DC Supply Voltage ... opt.2	+18V to 36Vdc	VDC
Signal In / Out connector	Term. Block	

Specifications		
Desc.		Unit
Current Output Adjustment Range	±100	mA
Current Output vs. Voltage Monitor Output	±10.0	mA / V
Max. Load Impedance @ ±100mA	200	ohm
Max. Load Impedance @ ±50mA	400	ohm
Max. Load Impedance @ ±10mA	2000	ohm
Max. Load Compliance Voltage	±20	V
Current Output Accuracy; BETTER THAN (@ 25C ±5C) Rload <= 100% of Max.	0.1	%
Current Output Manual Adj. Resolution	0.2	mA
Current Output: Drift; less than	20.0	nA / Deg.C
Voltage Output: Drift	30.0	uV / Deg.C
Voltage Output: Noise	35.0	uVp-p
Voltage Monitor Output: Impedance	600	ohm
Voltage Monitor Output: Max. load current	±10.0	mA

RDM-Apps Setup – PCB Revs.1.xx - CSE CSE00GL-100-xx-20V-BFL Constant Current Source / Sink Module.
Voltage to Current Converter Module.

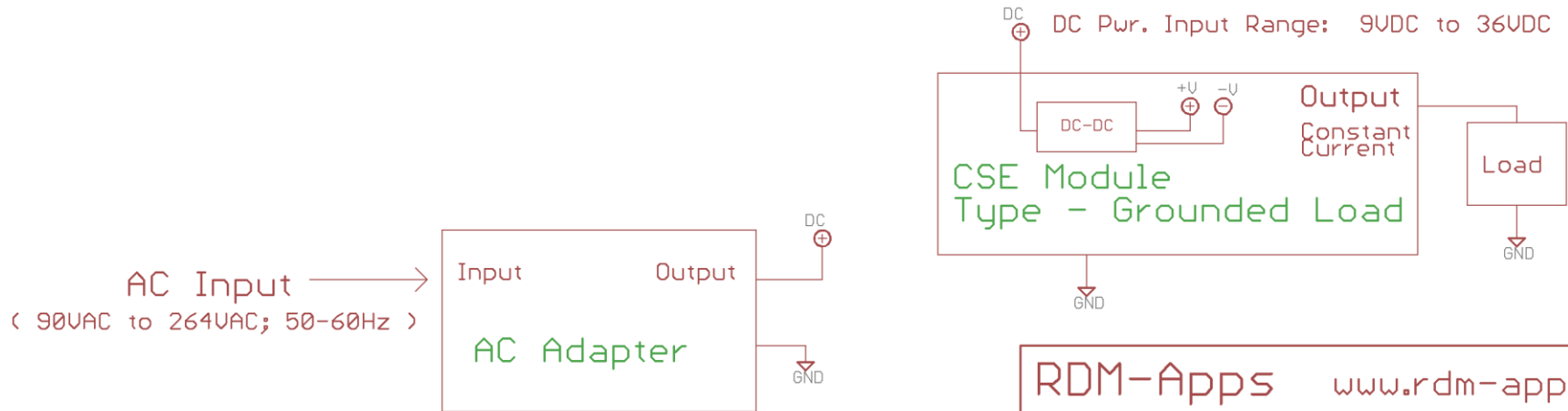
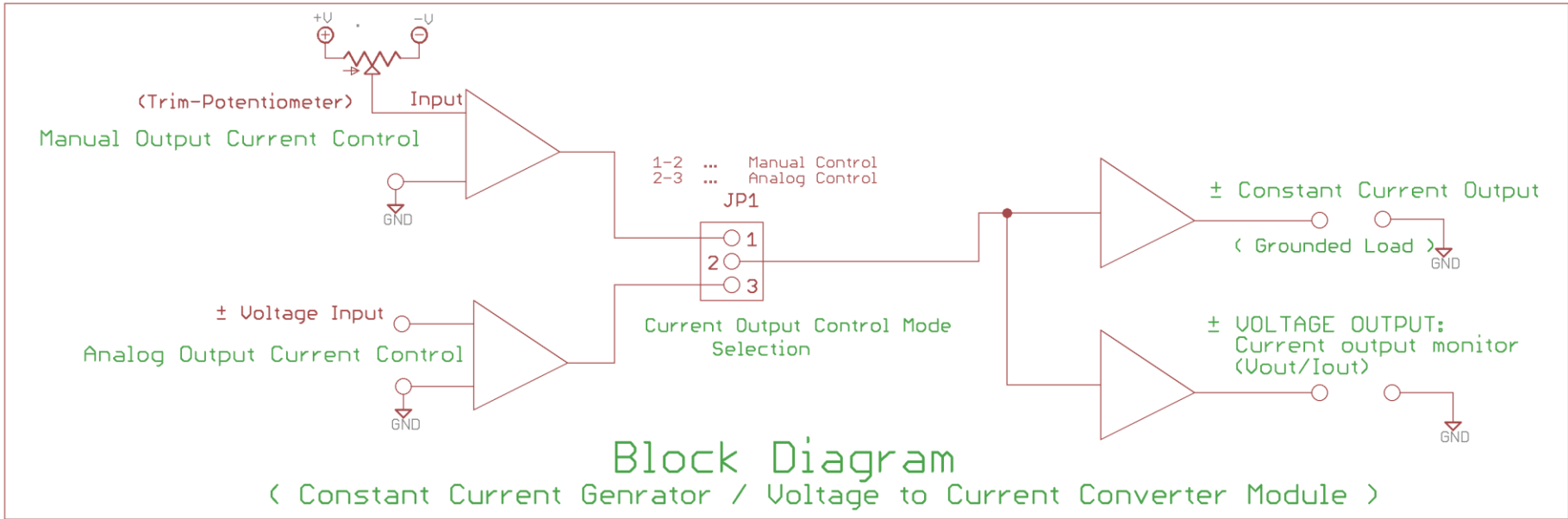

RDM-Apps		www.rdm-apps.com	
TITLE: CSE-Module Block Diagram-V1-7			
Document Number:			REV: 1.7
Date: 5/28/2018 6:33 PM			Sheet: 1/1

RDM-Apps Setup – PCB Revs.1.xx - CSE CSE00GL-100-xx-20V-BFL Constant Current Source / Sink Module.
Voltage to Current Converter Module.

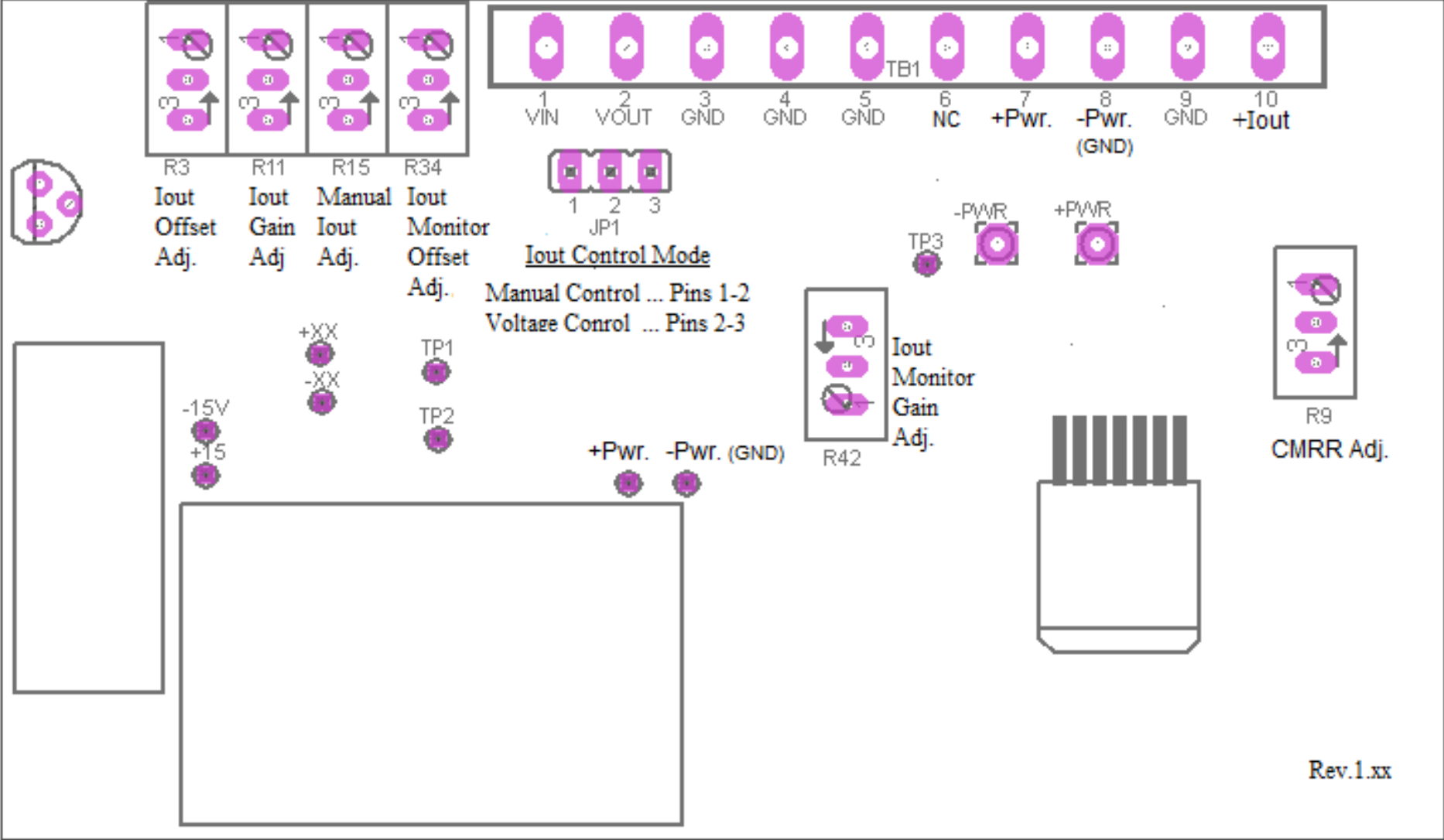

Rev.1.xx

**RDM-Apps Setup – PCB Revs.1.xx - CSE CSE00GL-100-xx-20V-BFL Constant Current Source / Sink Module.
Voltage to Current Converter Module.**

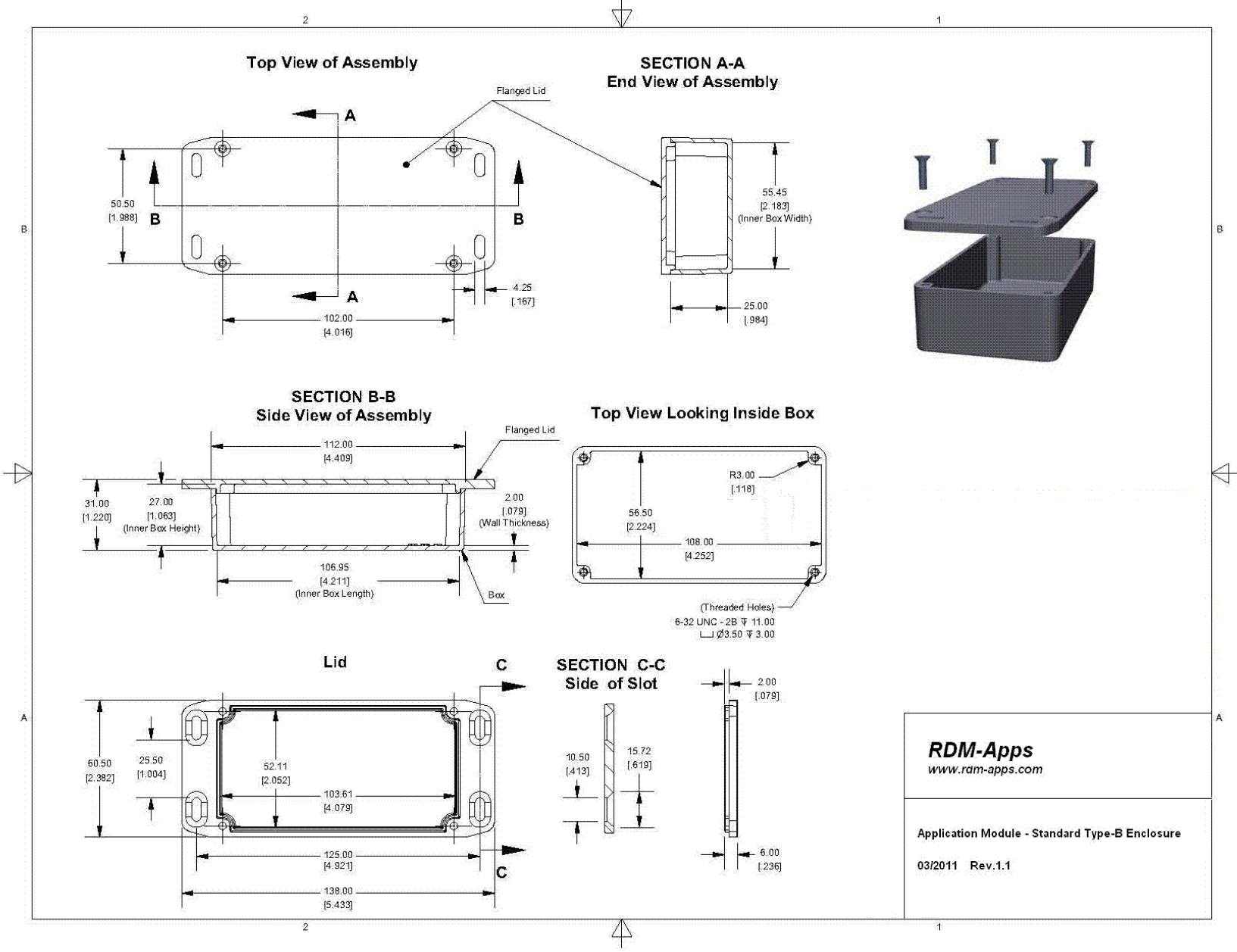

RDM-Apps
www.rdm-apps.com

Application Module - Standard Type-B Enclosure

03/2011 Rev.1.1

RDM-Apps Setup – PCB Revs.1.xx - CSE CSE00GL-100-xx-20V-BFL Constant Current Source / Sink Module.
Voltage to Current Converter Module.



Terminal Block Plug-In:
Part# OSTTJ105153 (Digikey) or
Part# 1757093 (Mouser)

Pluggable Terminal Blocks 10 Pos 5.08mm pitch Plug 24-12 AWG Screw

Gain / Offset Calibration Procedure:

Required equipment:

- 1.) An accurate ± 10 vdc voltage source.
- 2.) A current meter with accuracy better than 0.1% of the CSE full current range output.

Required Conditions::

- 1.) CSE Module must be jumpered for Analog Voltage Control Mode (JP1 pins 2-3).
- 2.) CSE Module must have required DC power applied.
- 3.) Connect voltage source to CSE module voltage input (Vin) connector.
- 4.) Connect current meter to the applicable CSE module current output (Iout) connector.
- 5.) Allow CSE module to warm up for at least 3 mins. Before continuing to the procedure.

Procedure exclusively for Grounded or Floating current outputs:

- 1.) Use your voltage source to apply 0.000V to the CSE voltage input (Vin) connector. Adjust "OFFSET" trim-pot until the CSE module current output (current meter) reads zero amps ... within 0.1% of the CSE full range output.
- 2.) Apply +5VDC to the CSE voltage input and adjust "GAIN" trim-pot to the required output current. For example, if your CSE module has a full range output of ± 100 mA and the Vin / Iout (Input / Output) ratio is 1V/10mA then the current output should be +50mA. Conversely , a -5VDC input should result in a -50mA output.

Note(s): you will probably have to repeat procedure steps 1 and 2 a couple of times to assure proper calibration. If the Gain adjustment potentiometer is set to one of the extreme top or bottom extents extremely high or low gain states can occur which may cause confusion when making sequential offset and gain adjustments. Also, we advise you adjust the gain using input voltages that are mid-range values.

Rev.1.3 07-19